

INSTRUCTION FOR O-Z/GEDNEY SEALING FITTINGS APPROVED FOR USE WITH: APPLETON "Kwiko® A" AND CROUSE-HINDS "Chico® A" SEALING CEMENT

- The National Electrical Code in Article 501 Section 501.15 Class I, Division 1 and 2, requires that seals be installed in specific locations. This is to prevent the passage of gases, vapors or flames through the conduit from one portion of the electrical installation to another portion.
- O-Z/Gedney sealing fittings are UL listed for use in hazardous locations with Appleton Kwiko A compound or Crouse Hinds Chico A compound only. These compounds, when properly mixed and poured, hardens into a dense and strong mass which is insoluble in water, is not attacked by petroleum products and is not softened by heat.
- The following sealing fitting series are UL listed for use with Appleton Kwiko A or Chico A sealing compounds: EYA, EYAM, EYD, EYDM, EY, EYM.

WARNING:

Failure to follow safety instructions may cause ignition of hazardous atmosphere resulting in serious personal injury and / or property damage.



Mineral Fiber Filler
"Asbestos Free"



"Asbestos Free" Sealing Cement.
Be sure to read the mixing
instructions on Sealing cement can.

STEP 1.

Install sealing fitting and pull conductors through.

- Remove plug(s) from sealing fitting and use fiber filler to make dam (s) in hub(s).

STEP 2.

DAMMING: Separate each conductor and pack fiber filler tightly into hub(s) behind conductors and around each conductor.

- These conductors must not touch each other nor the sealing fitting wall.
- Clean fiber shreds away from walls or conductors to prevent them from causing flame and / or leakage of gases. Finished dam must be flush with conduit hub bushing.

STEP 3.

Mixing: Prepare sealing compound using a completely clean mixing vessel in each batch. Shake the sealing cement thoroughly in all directions. Mix sealing cement with correct proportion of clean water as noted below.

APPLETON Kwiko A and CROUSE-HINDS Chico A CEMENT.

Add one (1) part water to two (2) parts cement by volume. Use cold water, warm water increases setting speed. Add water and stir immediately and thoroughly.

- **DO NOT** mix more than can be poured in 15 minutes after adding water.
- These cements are **NOT INSULATING COMPOUNDS** and **MUST NOT** be used for such purposes.

STEP 4

VERTICAL CONDUIT RUN. Pour sealing cement mixture into the small pipe opening until the cement is level with the last thread of the opening. Replace and tighten small pipe plug.

HORIZONTAL CONDUIT RUN. Pour sealing cement mixture into the sealing fitting through the large opening until two (2) to three (3) threads are covered with the cement.

- Replace and tighten in sequence the large pipe plug or cover the small pipe plug into the sealing fitting and the small pipe plug into the cover.

CAUTION

Refer to Table 1 to determine the maximum number and size of conductors allowed in a seal. (Page 4)

CAUTION: TEMPERATURE/CURE TIME

APPLETON Kwiko A and CROUSE-HINDS Chico A CEMENT

FOR GROUPS C AND D APPLICATIONS: Sealing compound to be mixed **ONLY** at temperatures above 35° F (1.7° C) and **ONLY** poured into fittings that have been brought to a temperature above 35° F (1.7° C). Seals must **NOT** be exposed to temperatures below 35° F (1.7° C) for a least 8 hours. Compound must be allowed 8 hours to cure to full strength before energizing system.

FOR GROUPS A AND B APPLICATIONS: Sealing compound to be mixed **ONLY** at temperatures above 40° F (4.4° C) and **ONLY** poured into fittings that have been brought to a temperature above 40° F (4.4° C). Seals must **NOT** be exposed to temperatures below 40° F (4.4° C) for a least 72 hours. Compound must be allowed 72 hours to cure to full strength before energizing system.

Damming and Pouring:

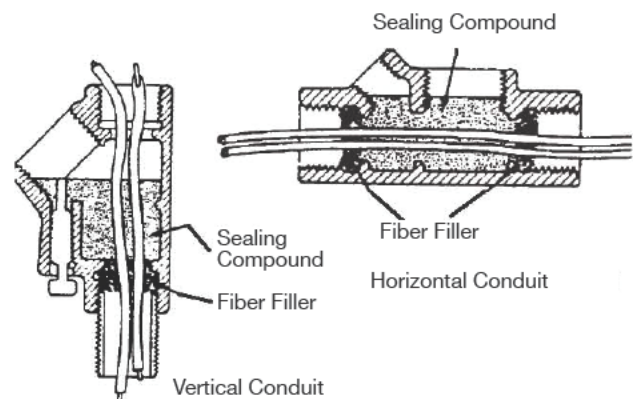

CAUTION

Remove any cement from threads in order to allow a minimum of 5 threads engagement of fitting threads, close plug and drain / breather.

EY AND EYM SEALING FITTINGS 1-1/4" TO 2" EXPLOSION-PROOF, DUST-IGNITIONPROOF FOR USE IN VERTICAL CONDUIT RUNS.

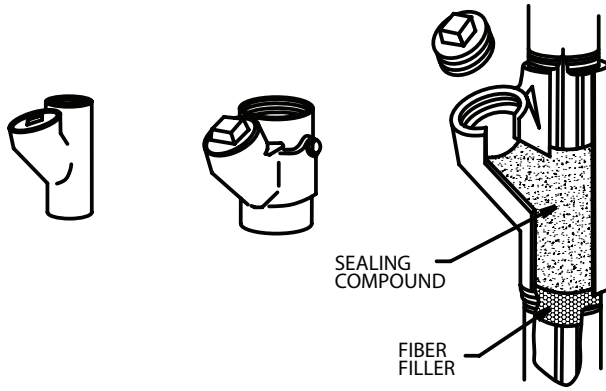

1. Install sealing fitting and pull conductors through.
2. Remove the large pipe plug. Tighten the small pipe plug on side of 3" and 4" sealing fitting sizes.
3. Dam the lower hub opening with Fiber Filler. (Page 1, Steps 1 & 2)
4. Mix sealing cement with the correct proportion of water per instructions provided with the cement. (Page 1, Step 3).
5. Pour Sealing Cement mixture into the sealing fitting opening until the cement is level with the last thread.
6. Replace and tighten pipe plug.

EYD AND EYDM SEALING FITTINGS 1-1/4" TO 4" EXPLOSION-PROOF, DUST-IGNITIONPROOF FOR USE IN VERTICAL CONDUIT RUNS.

EYD SERIES 1-1/4" TO 4" EYDM SERIES 1-1/4" TO 4"

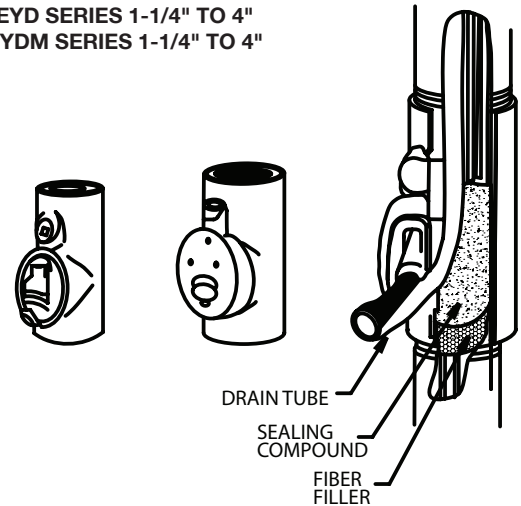

1. Install sealing fitting and pull conductors through.
2. Remove the large threaded cover from the sealing fitting.
3. Dam the lower hub opening with fiber filler. (Page 1, Step 2).
4. Replace the large threaded cover so that the threaded hole is facing downward.
5. Insert the tube and wire drain core into the opening of the large threaded cover so that the end being inserted will be above the compound in a completed seal. (See illustration above).
6. Be sure that the tube and wire drain core do not touch any of the conductors, Otherwise, this will expose the conductors in the completed and hardened seal. (See illustration above).
7. Mix Sealing Cement with the correct proportion of water per instructions provided with the cement. (Page 1, Step 3).
8. Pour Sealing Cement mixture into the sealing fitting through the opening located above the large cover until the last thread is covered with cement.
9. After cement has cured, (See page 1, "Caution: Temperature/ Cure Time") pull out the old tube and wire drain core and discard.
10. Thread the small pipe plug into this opening and tighten .
11. Thread ECDB drain-breather fitting into large cover threaded hole and tighten secure.

CAUTION

Remove any cement from threads in order to allow a minimum of 5 threads engagement of fitting threads, close plug and drain / breather.

EYA AND EYAM SEALING FITTINGS 1/2" TO 6" EXPLOSION-PROOF, DUST-IGNITIONPROOF FOR USE IN VERTICAL AND/OR HORIZONTAL CONDUIT RUNS.

VERTICAL CONDUIT

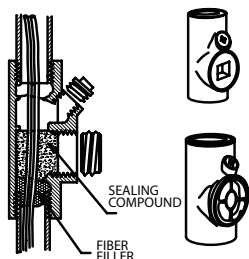

HORIZONTAL CONDUIT

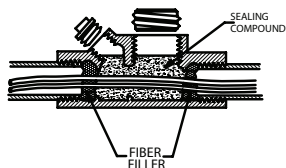

NOTE: On sizes 3", 3-1/2" and 4" the cover should be tightened down with the small pipe plug removed from it. This will allow excess cement or air to escape out rather than seeping through or pushing the dam into the conduit. When the large cover has been tightened fully, replace pipe plug.

Vertical conduit

1. Install sealing fitting and pull conductors through.
2. Remove the pipe plug where the cement will be poured through and the large pipe plug or cover with the small pipe plug for size 3-1/2"-6" at the center of the sealing fitting.
3. Dam the lower hub with fiber filler. (Page 1, Steps 1 & 2.)
4. Replace the large pipe plug or cover with the small pipe plug for 3-1/2" thru 6" and tighten all threaded joints securely.
5. Mix Sealing Cement with the correct proportion of water per instructions provided with the cement. (Page 1, Step 3).
6. Pour Sealing Cement mixture into the small pipe plug opening until the cement is level with the last thread of the opening.
7. Replace and tighten small pipe plug.

Horizontal conduit

1. Install sealing fitting and pull conductors through.
2. Remove all pipe plugs and / or cover from the sealing fitting.
3. Dam both hubs with fiber filler. (Page 1, Steps 1 & 2)
4. Mix Sealing Cement with the correct proportion of water per instructions provided with the cement. (Page 1, Step 3).
5. Pour Sealing Cement mixture into the sealing fitting through the large opening until 2-3 threads are covered with the cement. Fill hole must be oriented in the upright position.
6. Replace and tighten in sequence the large pipe plug or cover, the small pipe plug into the sealing fitting and the small pipe plug into the cover.

EYD AND EYDM DRAIN AND SEALING FITTINGS 1/2" TO 1" EXPLOSION-PROOF, DUST-IGNITIONPROOF FOR USE IN VERTICAL CONDUIT RUNS.

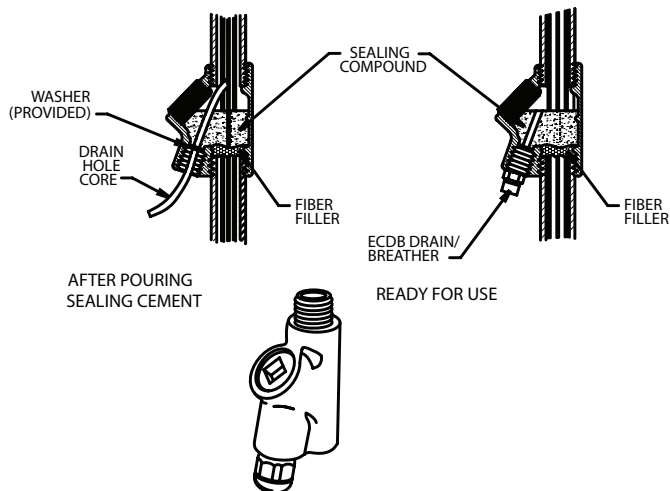

1. Install sealing fitting and pull conductors through.
2. Remove the pipe plug.
3. Dam the lower hub opening with fiber filler (See page 1, Steps 1 and 2).
4. Insert rubber drain-hole core through drain opening and washer (provided) high enough so inner end of core will be above sealing compound in completed seal.

Note: Washer (provided) must be inserted to last thread to form dam for sealing compound.

5. Be sure that the rubber drain - hole - core does not touch any of the conductors.
6. Mix Sealing Cement with the correct proportion of water per instructions provided with the cement (Page, 1 Step 3.).
7. Pour Sealing Cement mixture into the sealing fitting opening until the cement is level with the last thread of the opening.
8. Replace and tighten pipe plug.
9. When cement has cured (see page 1, "Caution: Temperature/ Cure Time") remove drain - hole - core.
10. Thread ECDB drain - breather fitting into threaded hole and tighten securely.

TABLE 1: MAXIMUM NUMBER OF CONDUCTORS THAT CAN BE SEALED IN A SEALING FITTING

- The maximum number of No. 4 Type THHN Conductors (Column B) in a 1-1/2" size sealing fitting is 6.
- The six (6) No. 4 THHN conductors represent the maximum wire fill of 25% or less for sealing fittings.
- Increasing the sealing fitting to a 2" trade size will provide space for the 40% wire fill, or nine (9) No. 4 conductors.

Example On How To Use Table 1: In our example, use an EWEVAM200 for 2" size EY / EYM, EYD, EYDM,

Trade Size	Conductor Size	Type	Max. No. Permitted for 25% Fill	Max. No. Permitted for 40% Fill/Trade Size Sealing Fittings Needed
1-1/2"	No. 4	THHN (Column B)	6	(9/2")

The Maximum number of wires that can be sealed in a fitting are as follows:

Size AWG or Kcmil	1/2" Seal (Qty/NPT Size)		3/4" Seal (Qty/NPT Size)		1" Seal (Qty/NPT Size)		1-1/4" Seal (Qty/NPT Size)		1-1/2" Seal (Qty/NPT Size)		2" Seal (Qty/NPT Size)		3" Seal (Qty/NPT Size)		3-1/2" Seal (Qty/NPT Size)		4" Seal (Qty/NPT Size)		5" Seal (Qty/NPT Size)		6" Seal (Qty/NPT Size)		
	A	B	A	B	A	B	A	B	A	B	A	B	A	B	A	B	A	B	A	B	A	B	
18	7	11	12	20	20	33	35	58	49	80	131	80	176	115	187								
16	6	9	10	16	17	27	30	47	41	64	106	68	150	98	151								
14	3	8	6	15	10	24	18	43	25	58	96	41	90	58	137	121	155						
12	3	6	5	11	8	18	15	32	21	43	71	34	76	50	102	103	132						
10	1	4	4	7	7	11	13	20	17	27	45	29	64	41	65	86	110	172	173				
8	1	2	2	4	4	6	7	11	9	16	26	16	35	22	37	47	60	100	94	157	137		
6	1	1	1	2	2	4	4	7	6	9	16	10	23	15	23	32	41	61	64	96	93	139	
4	1	1	1	1	1	2	3	4	5	6	8	8	18	12	14	24	31	37	49	59	72	85	
3																							
2																							
1																							
1/0																							
2/0																							
3/0																							
4/0																							
250																							
300																							
350																							
400																							
500																							
600																							
700																							
750																							
800																							
900																							
1000																							
1250																							
1500																							
1750																							
2000																							

* COL. A = Wire Types: RHH-2, RH, RHH, THW, TH, XHHW (AWG 14-6). COL. B = FEP, THHN, THWN, TFN, PF, PGFF, XHHW (AWG4-2000 MCM), FEPBV (AWG 14-8).

NOTE: For all other conductor sizes and types, wire fill is based on maximum 40% fill or less depending on conduit size and conductor type per the NEC Code.

• For all other conductor sizes and types, wire fill is based on maximum 25% fill or less.